

Development of Energy Models for Production Processes and Systems to Inform Environmentally Benign Decision-Making

Funding Sources: Industrial affiliates of LMAS

Introduction and Motivation

- Manufacturing consumes about one-third of U.S. energy [EIA 2012] and is responsible for 19% of total world GWP emissions [Herzog 2005].
- By understanding the energy consumed at each level of manufacturing, better strategies can be designed and implemented for energy consumption reduction.

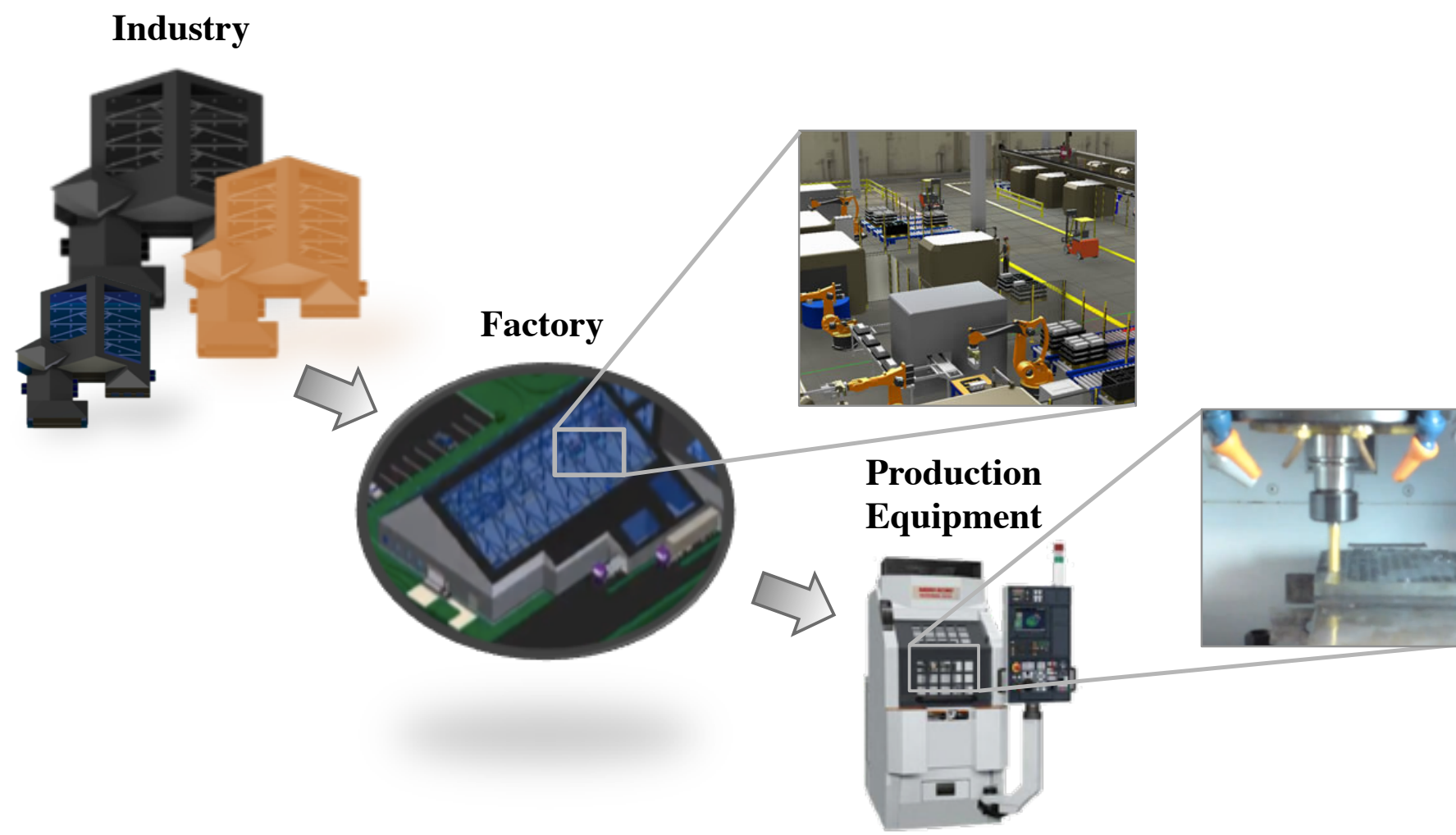

Energy Prediction for Production Equipment

- The energy of production equipment was found to be inversely proportional to the material removal rate (MRR).
- This energy model was verified for variable MRR profiles. The average accuracy was found to be 97.4%, deeming the model appropriate for use in estimating the energy of machined parts.

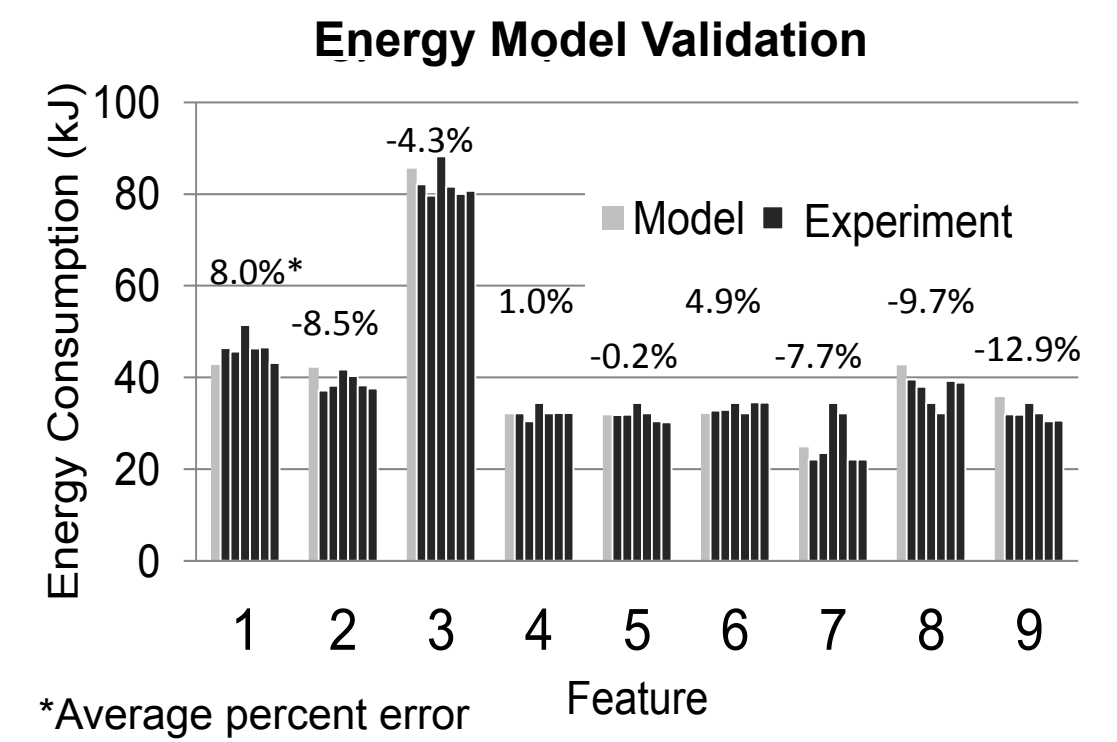
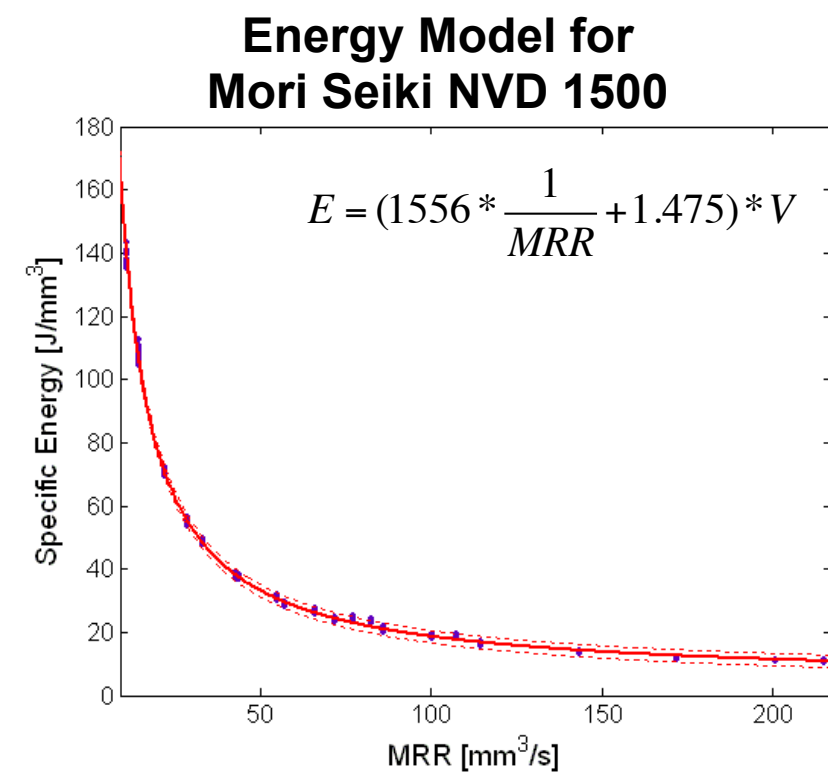
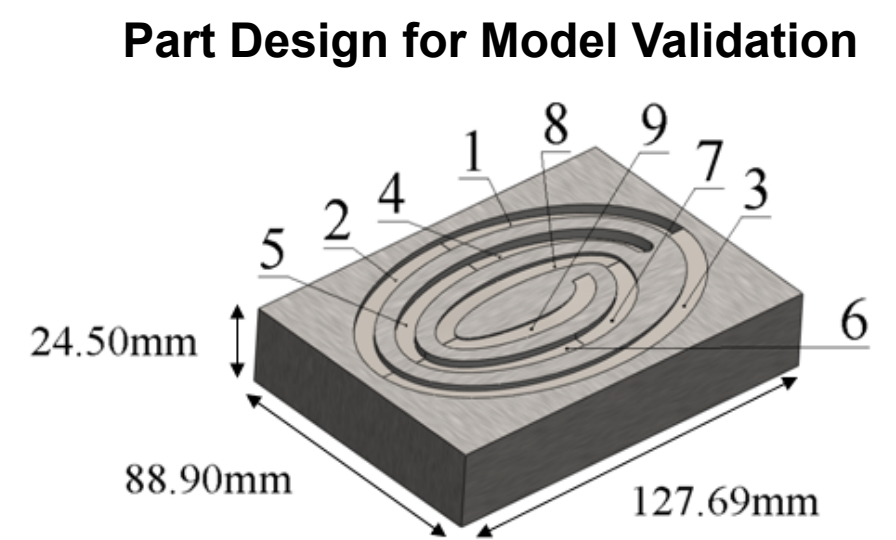

Machine Scheduling for Energy Reduction

- At the factory level, a machine tool prioritization algorithm was developed and implemented in a discrete event simulation environment to reduce energy.
- The "Baseline Case" consisted of five cells (M1-M5) with milling machine tools.
- Machine selection was dictated by the estimated process energy, machine availability and machining capability. If no machines capable of manufacturing the part were available, parts entered the shortest queue.
- The process and idle energy of the machine tools was simulated for seven scenarios, in which the number of machines per cell were modified.
- Energy savings of up to 8.5% were realized.
- The optimal scenario was found to reduce energy by 6.4% while maintaining a stable queue length.

Energy Breakdown for "Baseline Case"

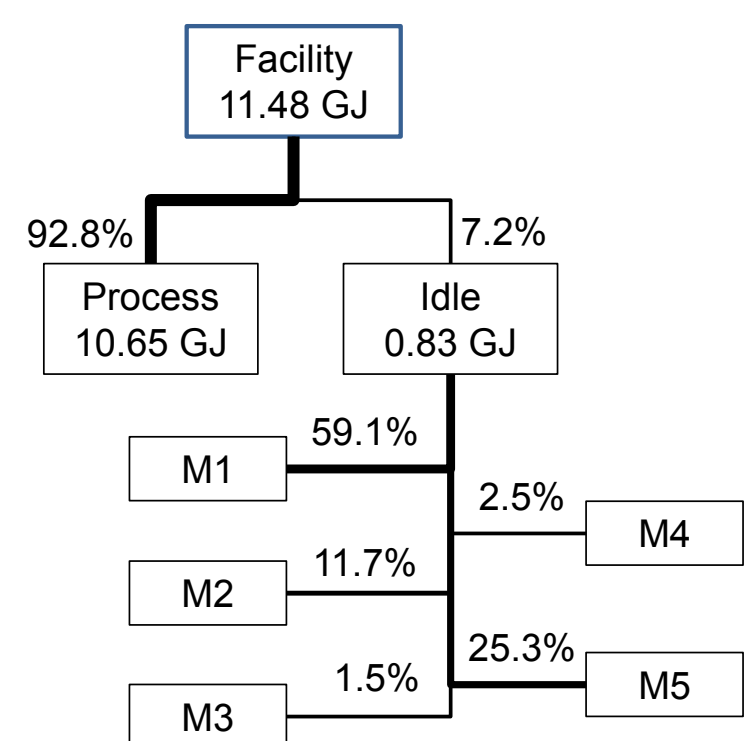

Impact of Machine Utilization on Energy

- The extent of machine use affects the breakdown of energy consumption in a facility. As shown below with Mori Seiki factory data, the increased use of machines increases the relative proportion of energy for machines.

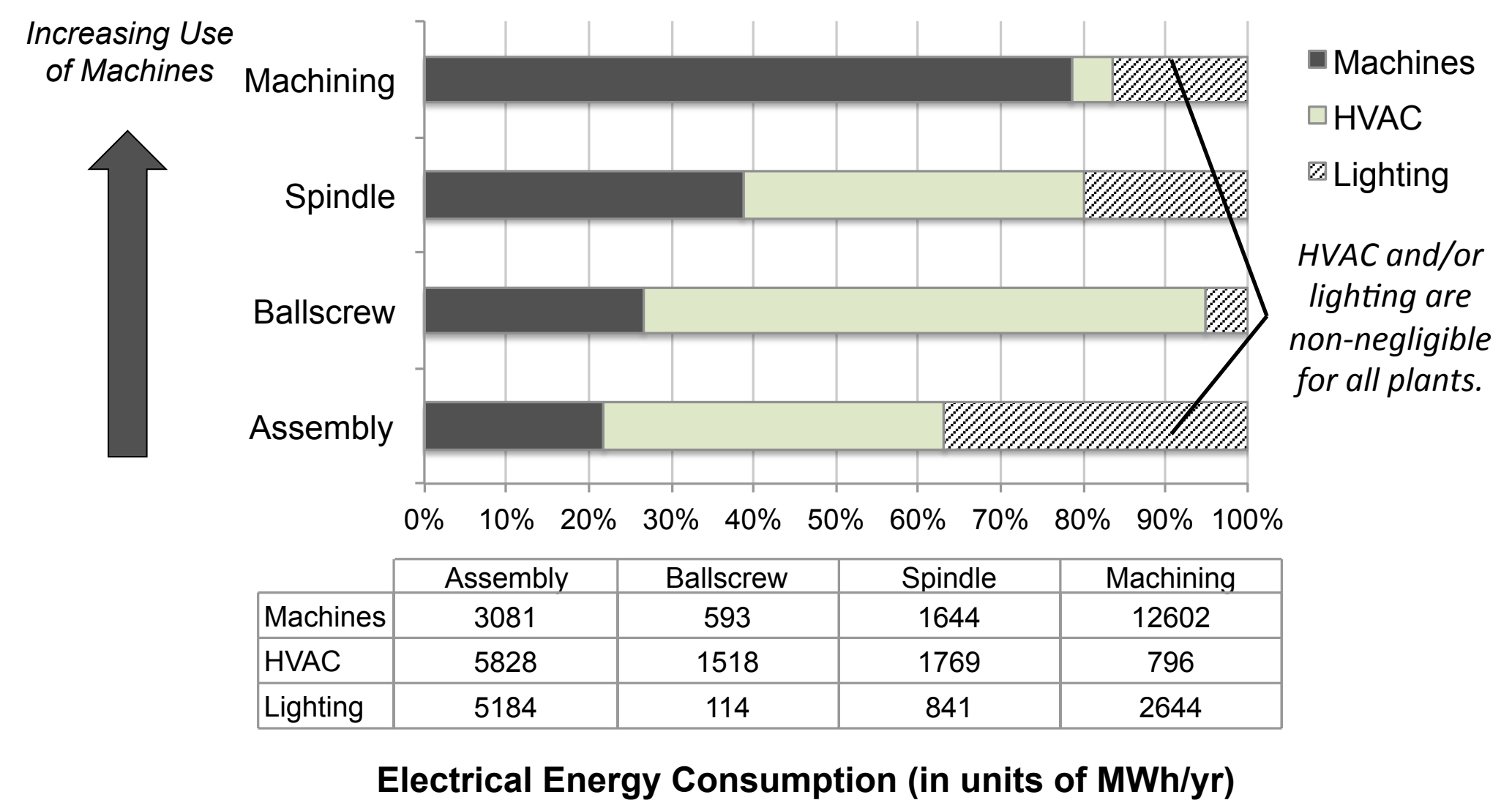

Electrical Energy Intensity

- The electrical energy used to operate machines, HVAC, and lighting with respect to the floorspace is shown for the Mori Seiki machine tool manufacturing plants and for facilities of selected industries in the U.S.

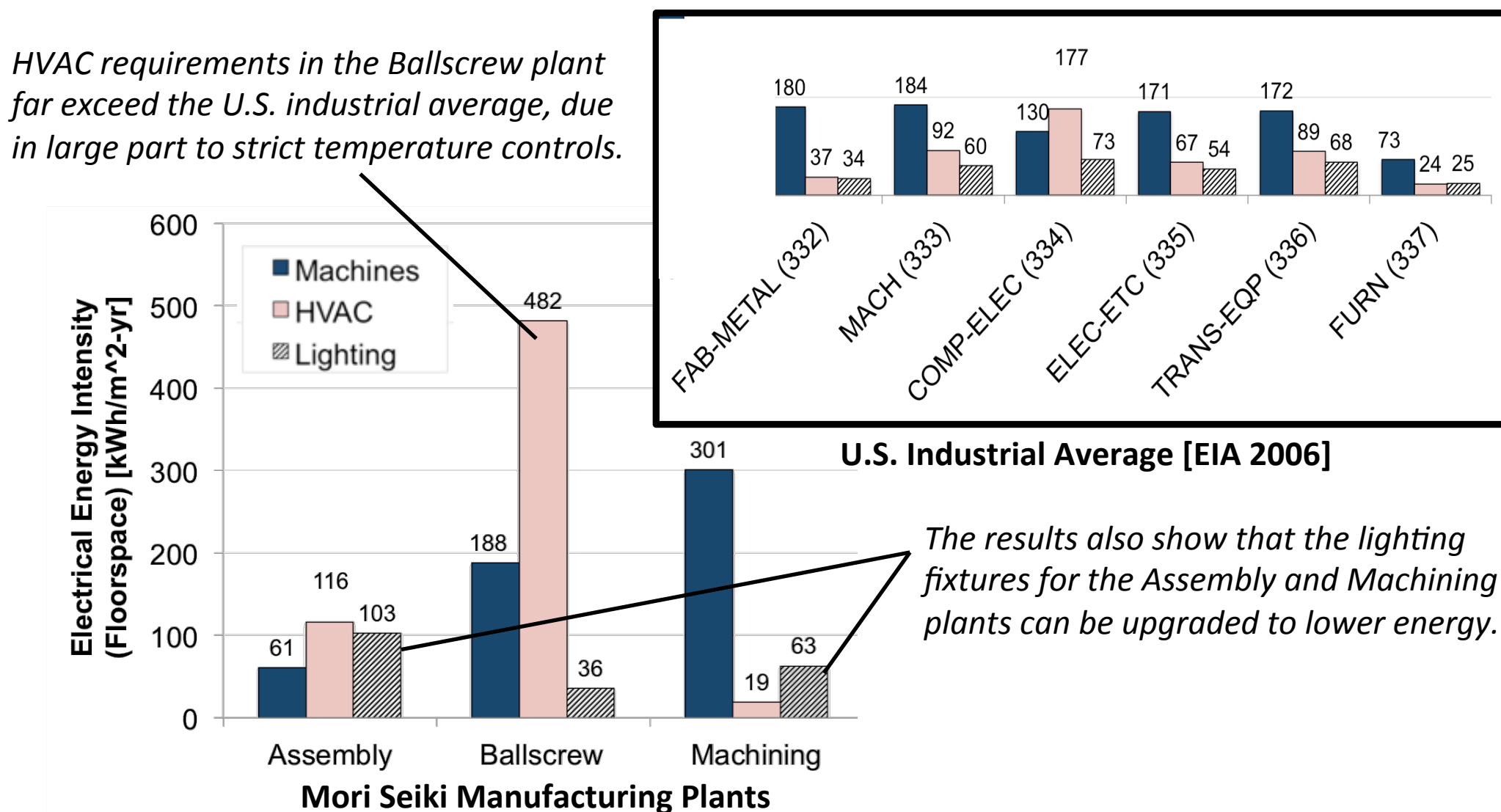

HVAC Energy Model Development

- The monthly HVAC energy requirements can be correlated to the average outside temperature and the production volume.

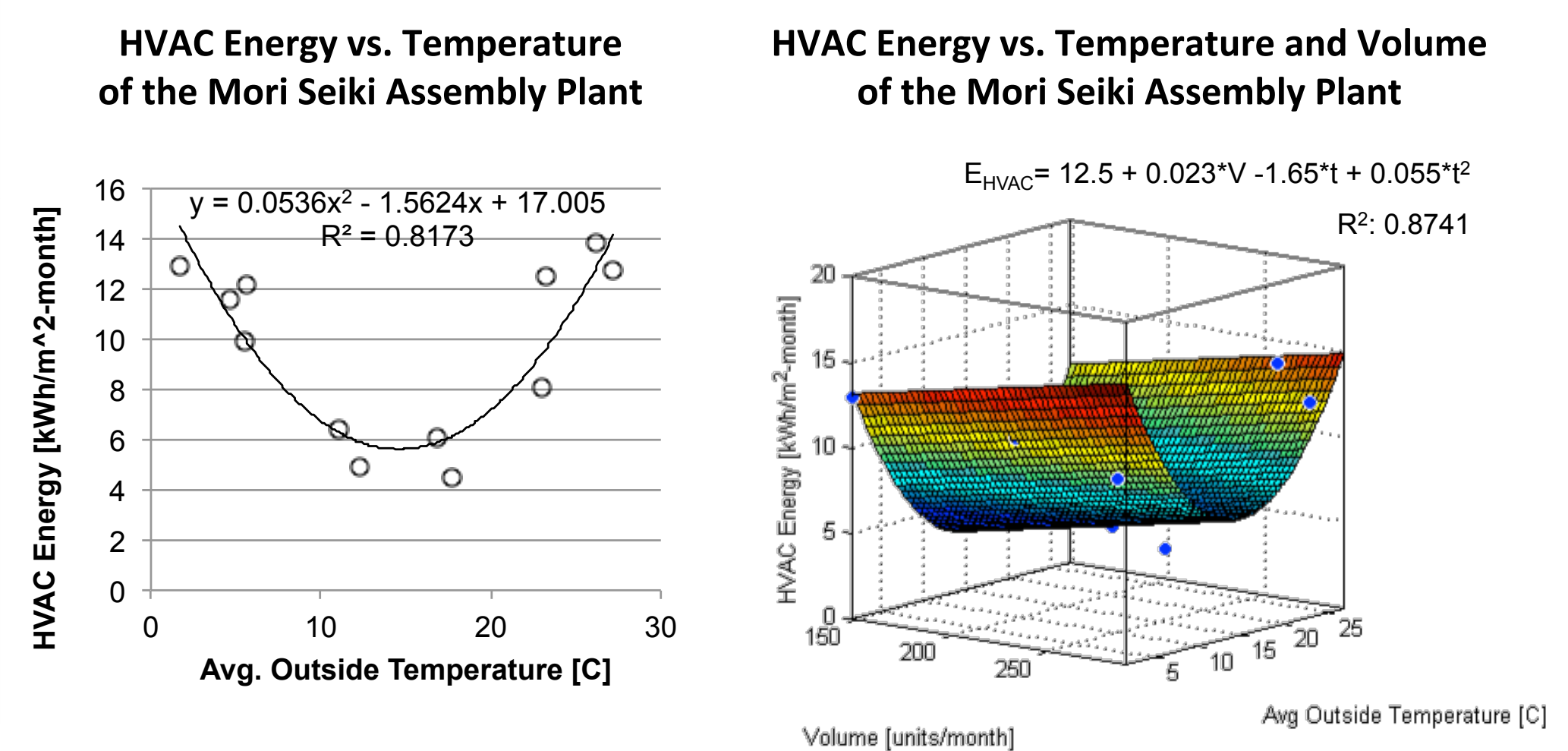

Impact of Factory Siting Decisions

- A case study was developed to assess the effect of factory location on electricity, greenhouse gas (GHG) emissions, and cost for machinery manufacturing.
- The HVAC energy model and the average, industrial energy intensities from U.S. sites were used in the study.
- Emissions were highest for sites using primarily fossil fuels (i.e., Detroit, Shanghai, and New Delhi); these sites also had higher HVAC energy requirements.
- Labor costs dominated manufacturing costs in most cases, but electricity costs were dominant in developing countries.

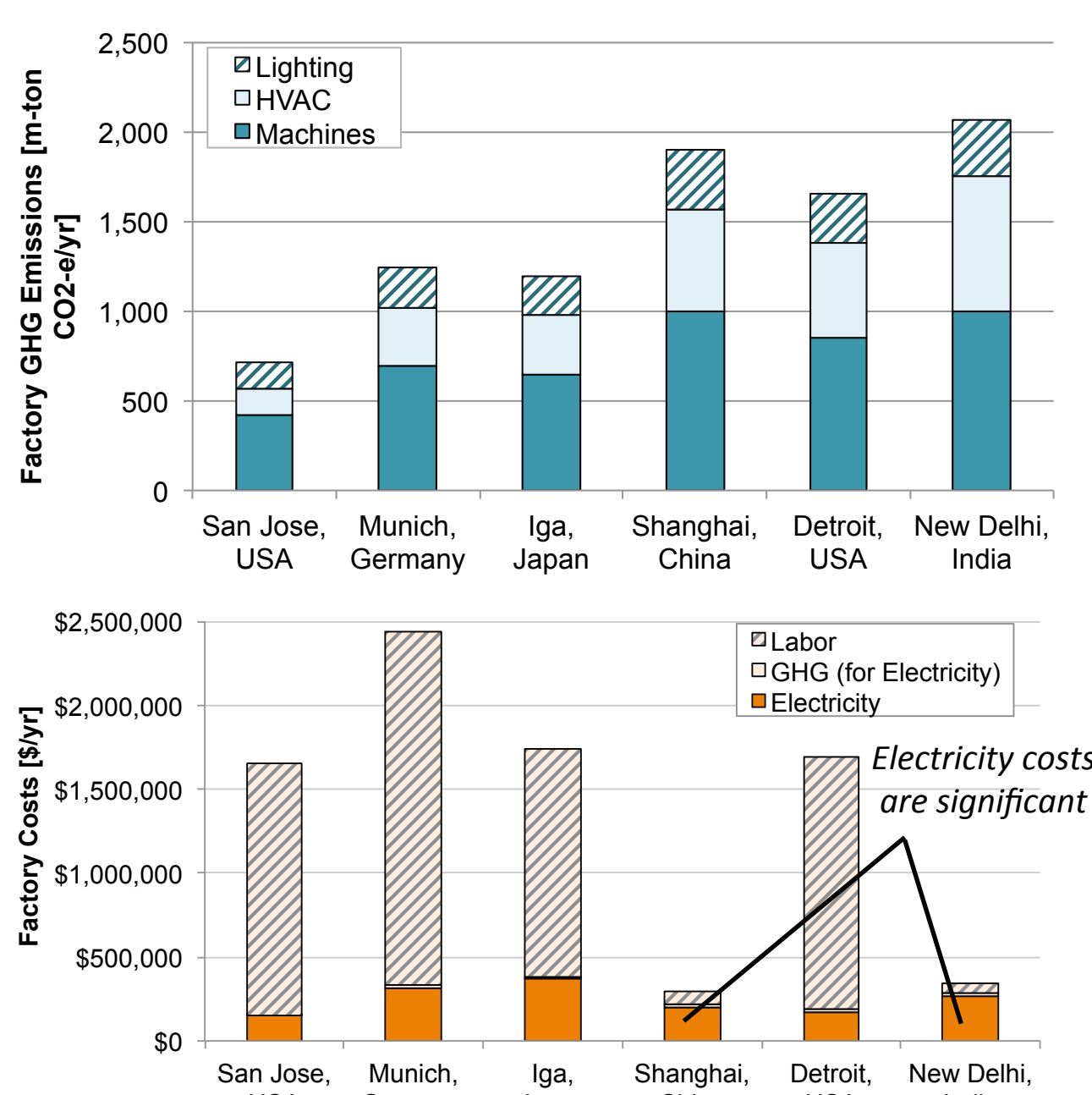

Summary and Future Work

- Summary of Contributions:
 - Developed a methodology to estimate the energy of machining.
 - Designed and implemented a machine tool prioritization algorithm.
 - Assessed the impact of machine utilization and trends in energy intensity in manufacturing.
 - Developed an energy model for HVAC requirements for the factory.
 - Analyzed the effect of siting decisions on electricity, GHG emissions, and costs.
- Recommendations for Future Work:
 - Facilitate data acquisition at the facility level.
 - Build factory models to study the impact of automation on energy.
 - Integrate water consumption, availability, and associated energy consumption for cleaning and distribution into analyses.
 - Extend the use of the energy models and reduction strategies to other industries and types of operations.